

CookSafeTM

The World's Safest Range Hood!



INTRODUCING THE FIRST INTEGRATED RANGE HOOD & FIRE SUPPRESSION SYSTEM FOR RESIDENTIAL RANGES!



Fire Starts:

NFPA estimates that there are over 12 MILLION cooking fires annually in the US (most of them unreported) resulting in over 640,000 injuries. CookSafe was created to address this critical need, preventing injuries, saving property and bringing comfort to families and property owners alike.



System Activates:

The patented CookSafe system monitors the stovetop temperature continuously and delivers 3 levels of protection:

- > At the 1st Temp set point, the powerful fan turns on HIGH to exhaust and control the heat;
- > At the 2nd Temp set point, Cooksafe shuts the stove OFF (gas or electric) and activates the alarm;
- > At the 3rd Temp set point, the potassium based extinguishing agent is released, targeting the burners and suppressing the fire!



Fire is Out!

The patented **CookSafe** system delivers an impressive set of features to safeguard your home or occupancy. Designed to complement designer kitchens with elegant styling, the under-cabinet unit **prevents injuries** and virtually **eliminates property damage** from a fire or sprinkler discharge.

CookSafe is Dealer Installed and Serviced

Listed and Tested to UL 300A, UL507 Standards and is NSF approved

Perfect for:



Limited Commercial, Elderly Housing, Apartments, Condominiums, Dormitories, Hospitality and anyone who never wants to risk having a cooking fire again !





Design Features -

- Easily installed by securing back mounting plate to wall and mounting hood assembly to plate.
- Commercial grade components throughout plus brushed stainless construction;
- Stainless steel self-draining baffle impingement filter and drip cup.
- Fan can be set up for recirculation or remote discharge of cooking vapors. Remote fan available.
- Unit and ductwork are easily removed or accessed for cleaning.
- Remote pull, audible and visual capabilities plus signaling to central station, fire alarm panel or dialer
- Powerful 500 CFM Fan and 60W Shatter-proof Bulb
- UL300A, UL 507 & NSF Listed through ETL/SEMKO

System Requirements -

- 115 VAC / 5 A / Single Phase Operation
- 7" Dia or 3-1/2" x 12" Vent connection (Optional)
- Alarm System connection (Optional) - dry contact
- 1/2"- 115 VAC Gas Line Valve - OR
- 50A - 115 / 220VAC Relay Contactor Included



Physical Data -

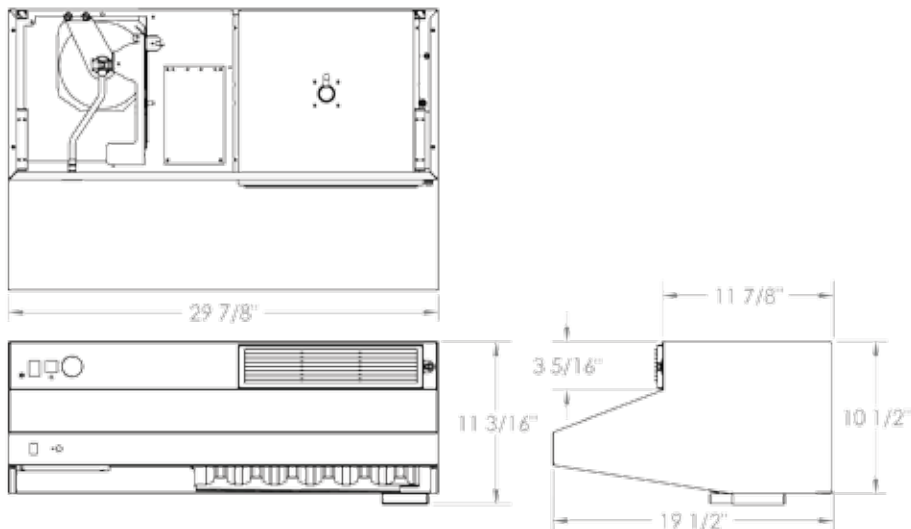

For Sales and Distribution Opportunities, contact:

www.cooksafe.com

CookSafe

20 Denlar Drive
Chester, CT 06412

(p) 860.526.9846

(f) 860.526.8352

sales@cooksafes.com